



# KONA 5

Take command of the most challenging projects using the immense power of KONA 5, AJA's blazingly fast I/O card, designed for today's most demanding video and audio workflows.

**\$4069** US MSRP

Whether you are working with 8K/UltraHD2, 4K/UltraHD, 2K/HD, SD, Deep Color, HFR and/or HDR, experience the quality and peace of mind that KONA 5 brings to your world. Supporting 10-bit 4:2:2 and 12-bit 4:4:4 color spaces for pristine imagery, KONA 5 allows the flexibility to ingest and output with 12G/6G/3G-SDI and monitor with a full-size HDMI 2.0 port. The bidirectional 12G-SDI ports provide immense flexibility for capture and simultaneous pass through, and with the appropriate software, multi-channel capture and streaming.

For HDR workflows, KONA 5 supports HDR10+, HLG, PQ, and Dolby Vision for rich color delivery over SDI and/or HDMI. KONA 5 has the power for the work you do today and into the future.

<https://www.aja.com/products/kona-5-oem>

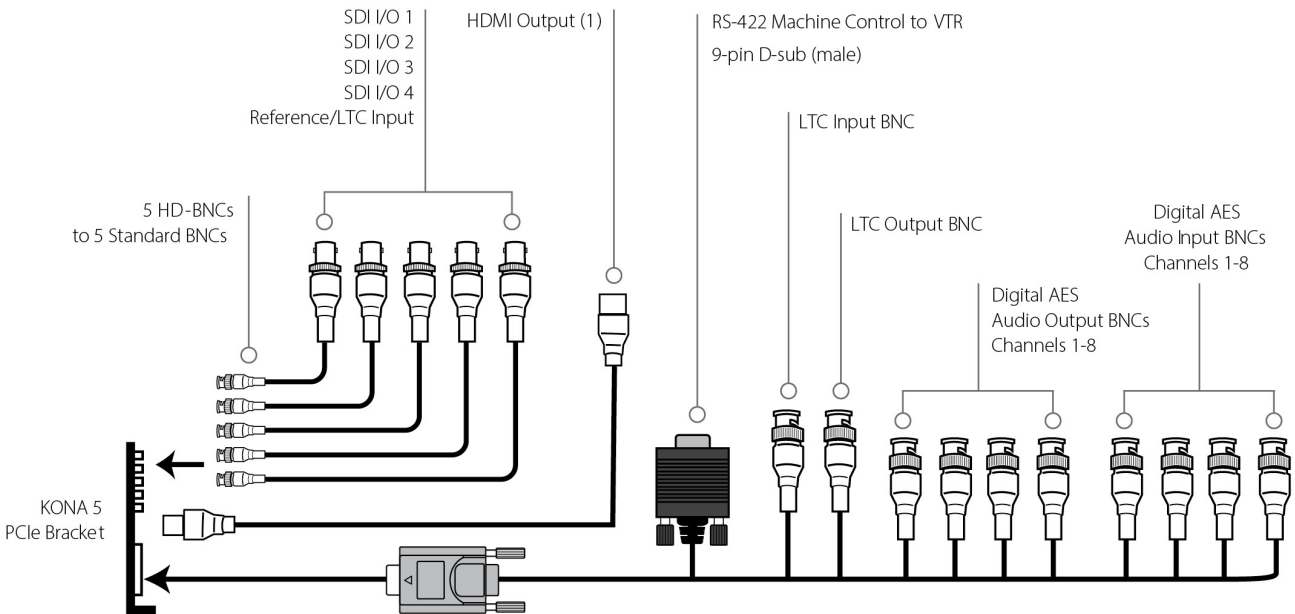

## Video Formats

- (8K) 8192 x 4320p 23.98, 24, 25, 29.97, 30, 47.95, 48, 50, 59.94, 60
- (UltraHD2) 7680 x 4320p 23.98, 24, 25, 29.97, 30, 50, 59.94, 60
- (4K) 4096 x 2160p 23.98, 24, 25, 29.97, 30, 47.95, 48, 50, 59.94, 60
- (UltraHD) 3840 x 2160p 23.98, 24, 25, 29.97, 30, 50, 59.94, 60
- (2K) 2048 x 1080p 23.98, 24, 25, 29.97, 30, 47.95, 48, 50, 59.94, 60
- (2K) 2048 x 1080PsF 23.98, 24, 25
- (HD) 1080p 23.98, 24, 25, 29.97, 30, 50, 59.94, 60
- (HD) 1080PsF 23.98, 24, 25, 29.97, 30
- (HD) 1080i 50, 59.94, 60
- (HD) 720p 50, 59.94, 60
- (SD) 625i 50
- (SD) 525i 59.94

**Note:** High Frame Rate and 8K/UltraHD2 capabilities are dependent on host system attributes. Not all systems and configurations will support all frame rates and raster sizes.

## Video Inputs Digital

- 12G-SDI, SMPTE-2082, 12-bit\*, 10-bit
- 6G-SDI, SMPTE-2081, 10-bit
- 3G-SDI, SMPTE 425
  - RGB 4:4:4 12-bit\*, YCbCr 4:2:2 10-bit
- 1.5G-SDI, SMPTE 292M
  - Single Link HD-SDI YCbCr 4:2:2 10-bit
  - Dual Link RGB 4:4:4 12-bit\*, Dual Link YCbCr 4:2:2 10-bit
- 270 Mbps SDI, SMPTE 259M-C
  - YCbCr 4:2:2 10-bit, 8-bit

\*Bit depth support is application dependent. Check with your software manufacturer for compatibility.

**Note:** KONA 5 SDI connectors are HD BNC

## Video Outputs Digital

- 12G-SDI\*, SMPTE-2082, 12-bit\*, 10-bit
- 6G-SDI\*, SMPTE-2081, 10-bit
- 3G-SDI, SMPTE 425
  - RGB 4:4:4 12-bit\*, YCbCr 4:2:2 10-bit
- 1.5G-SDI, SMPTE 292M
  - Single Link HD-SDI YCbCr 4:2:2 10-bit
  - Dual Link RGB 4:4:4 12-bit\*, Dual Link YCbCr 4:2:2 10-bit
- 270 Mbps SDI, SMPTE 259M-C
  - YCbCr 4:2:2 10-bit, 8-bit
- HDMI v2.0
  - 30/36-bits/pixel, RGB or YUV, 6 Gbps per color component
  - 4K, UltraHD, 2K, HD, and SD with HFR support up to 60p (4:2:2), 10-bit

\*Bit depth support is application dependent. Check with your software manufacturer for compatibility.

**Note:** KONA 5 SDI connectors are HD BNC

## HDR

- SDI: VPID signaling for SDR/HDR Transfer Characteristics, Colorimetry and Luminance
- HDMI: HDR10 Support - HDR Infotone metadata, compatible with HDMI 2.0a/CTA-861.3
- HDMI: HLG Support - compatible with HDMI 2.0b/CTA-861-G

**Note:** HDR support is application dependent. Check with your software manufacturer for compatibility.

## SDI I/O

- SDI connections are bidirectional
  - 2K/HD, capture and monitoring is simultaneous
  - 4K/UltraHD with 12G-SDI, capture and monitoring is simultaneous.
  - 4K/UltraHD with 3G-SDI, all four connections must be used for either Input or Output.
  - 8K/UltraHD2 with 12G-SDI, connections must be used for either Input or Output.

**Note:** When connections are configured for 12G-SDI or 6G-SDI, only UltraHD/4K/UltraHD2/8K formats are supported.

## Audio Inputs Digital

- 16-channel, 24 and 16-bit SDI embedded audio, 48 kHz sample rate, synchronous
- 8-channel, 16 and 24-bit AES/EBU audio, 48 kHz sample rate, synchronous or nonsynchronous, internal sample rate conversion (via 4x BNC on breakout cable)

## Audio Outputs Digital

- 16-channel, 24-bit SDI embedded audio, 48 kHz sample rate, synchronous
- 8-channel, 24-bit HDMI embedded audio, 48 kHz sample rate, synchronous
- 8-channel, 16 and 24-bit AES/EBU audio, 48 kHz sample rate, synchronous or nonsynchronous, internal sample rate conversion (via 4x BNC on breakout cable)

## Downstream Keyer

- Supports graphics up to 2K/HD with alpha channel over video, matte or framebuffer, or framebuffer content over incoming video or matte

## Reference

- Analog Color Black (1V) or Composite Sync (2 or 4V) or HD Tri-Level Sync (1V) (via 1x HD-BNC at PCIe bracket)
- Reference input is terminated into 75 ohms when Genlock is set to Ref In

## Timecode

- LTC timecode input and output (via 2x BNC on breakout cable)
- LTC timecode input (via 2-pin header on PCIe card)
- LTC timecode input (via HD-BNC at PCIe bracket)

## Electrical Interface

- 8-lane PCIe 3.0

## Machine Control

- RS-422, Sony 9-pin protocol (via breakout cable)
- 9-pin D-connector pinout is as follows:

1	GND
2	RX-
3	TX+
4	GND
5	No Connection
6	GND
7	RX+
8	TX-

9	GND
Shell	GND

## Noise

---

- <50dBA (A-weighted at 1m in free air)

## Size (w x d x h)

---

- 0.75" x 6.9" x 5.0" (19.05 x 175.26 x 127.00 mm)

## Weight

---

- PCIe Card: 0.6 lbs (0.3 kg)
- Cables (all combined): 1.3 lbs (0.6 kg)

## Power

---

- 28W typical, 35W maximum
- PC Internal ATX Power Connector (Molex p/n 45559-0002)

**Note:** Unlike other KONA cards, KONA 5 uses PCIe power from a 6 pin ATX connector, or from the PCIe slot.

## Environment

---

- Safe Operating Temperature: 0 to 40 C (32 to 104 F)
- Safe Storage Temperature (Power OFF): -40 to 60 C (-40 to 140 F)
- Operating Relative Humidity: 10-90% noncondensing
- Operating Altitude: <3,000 meters (<10,000 feet)